



Merus™ A2

Active Harmonic Filter

TECHNICAL



Power quality

and its solutions

Power quality is becoming a critical issue in electrical environments as industry, automation and machinery are constantly increasing. Every day, more variable frequency drives (VFD) and other non-linear loads are being connected to electrical networks. They get more sensitive to poor power quality issues that they often generate themselves. Poor power quality can cause severe economic and technical issues.

Typical power quality problems are:

- **Overheating of equipment**
- **Poor performance and malfunctions**
- **Decreased lifespan of devices**
- **System heat losses**
- **Overdimensioning of the electrical feeder**
- **Power cuts**

Most of the countries worldwide have power quality standards and recommendations in place, such as IEEE519, G5/4 and EN 50160. These require the power quality to be always kept within the prescribed range in order for electrical systems to function in their intended manner without any issues.

Basically, power quality issues can be divided into three main categories:



HARMONICS



REACTIVE POWER



UNBALANCE

Merus™ A2-Active Harmonic Filters operate similarly to noise-canceling headphones. They measure the distorted current of the non-linear load and inject harmonic frequencies, but with an opposite phase angle. Canceling out harmonic currents reduces voltage harmonics and eliminates distortion at the point of common coupling.

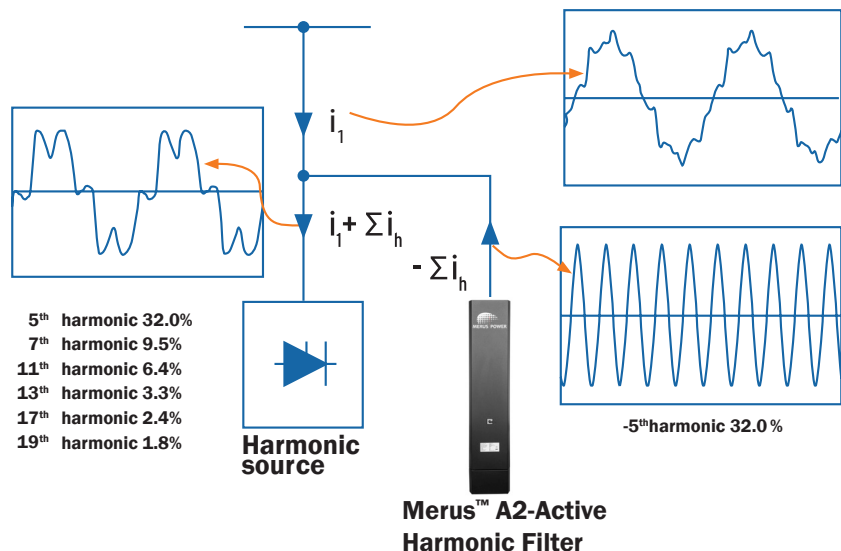

Harmonics

Current harmonics in the network (multiples of fundamental current e.g., 5th 250 Hz, 7th 350 Hz) create:

- **Voltage distortion when going through the feeding transformer**
- **Heating of electrical components such as transformers and motors**
- **Causes Tripping of the protection and control devices**
- **Abnormal amount of neutral currents**
- **Heat losses**

Both current and voltage harmonics are often required to be within suitable ranges according to electrical standards and recommendations. Harmonic voltage also improves via mitigating harmonic currents.

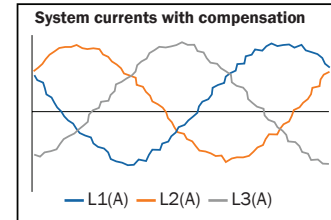
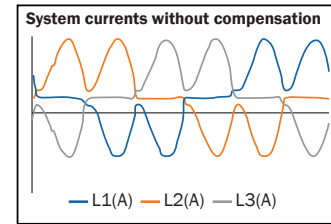

Reactive power

- **Reactive power consumes electrical network capacity**
- **Rapid changes create voltage flicker and voltage fluctuations**
- **Excess amount of reactive power might result in an unnecessarily-sized electrical feeder or generators**

Excessive amount of reactive power can be penalized from the customer depending on local regulations.

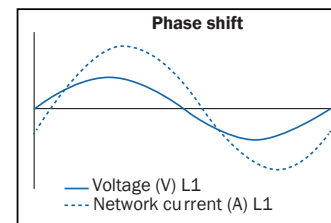
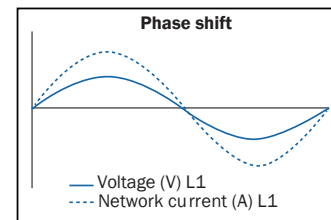

Unbalance

Mains current unbalance creates:

- **Current imbalance creates voltage unbalance**
- **Can lead to overdimensioning of the transformer or force a redesign of the existing network**
- **Overheating of the electrical devices**

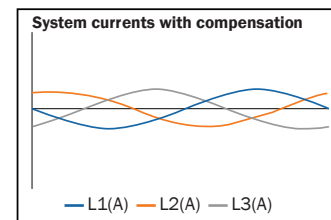
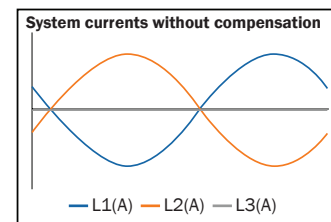

Merus™ A2 is the ultimate solution for these problems in one, well-tailored package.

- **Harmonic mitigation (Typical solution AHF)**
- **Power factor control (Typical solution SVG)**
- **Unbalance mitigation (Typical solution ALB)**

Power quality issues rarely occur alone, but the challenges are interrelated. For this reason, we have designed a device that can reduce multiple power quality issues, and not just one.

Merus™ A2-Active Harmonic Filter is the perfect single device to ensure good power quality.

Merus Power

Electrify your Future

Merus Power is a global green technology company headquartered in the city of Nokia, Finland. We design, manufacture, sell and provide power quality systems and services as well as Finnish innovative electrical energy storages. Scalable and modular power electronics, intelligent software technologies and electrical engineering expertise are the basis of our business.

The fruit of our operating experience of over 10 years and continuous product development is an extensive and specialized product portfolio that meets the increased demand of megatrends. Our solutions are based on scalable technology, which enables the use of our products and services in a wide range of different application needs.

- 2008** Merus Power was founded to meet the challenges of industrial power quality and connecting wind power to the electrical grid. Our operations focused on power electronics, advanced software technologies, and electrical engineering expertise, as well as their application to energy savings and productivity improvements in industry and real estate.
- 2010** We launched our very first delivery in the fall of 2010, delivering Merus™ Active Filters to a large domestic industrial operator.
- 2011** We completed our first international customer deliveries to Taiwan, China and the United Kingdom.
- 2017** **We launched our new modular Merus™ A2-series Active Harmonic Filters.**
- 2018** We reached a significant milestone when we delivered one of the world's largest active filters to a wind farm in Australia.
- 2021** We became a publicly listed company. Trading of our shares began on the Nasdaq First Growth Market Finland on June 8, 2021.

We hold a profound local and global presence as well as a strong industrial order backlog in power quality solutions. Over the years, we have delivered our innovative solutions to 59 countries around the world to various customers and successfully mitigated all sorts of power quality issues.

Our values

- Passion for technology
- Appreciation and trust
- Meeting customer needs
- Clean future

Why choose Merus Power?

- Over 13 years of experience in power quality and engineering
- Profound local and global presence
- Strong industrial order backlog in power quality solutions
- Cost-effective and economical 21st-century technology
- Top-quality and scalable solutions made with Nordic excellence
- Customer-oriented approach

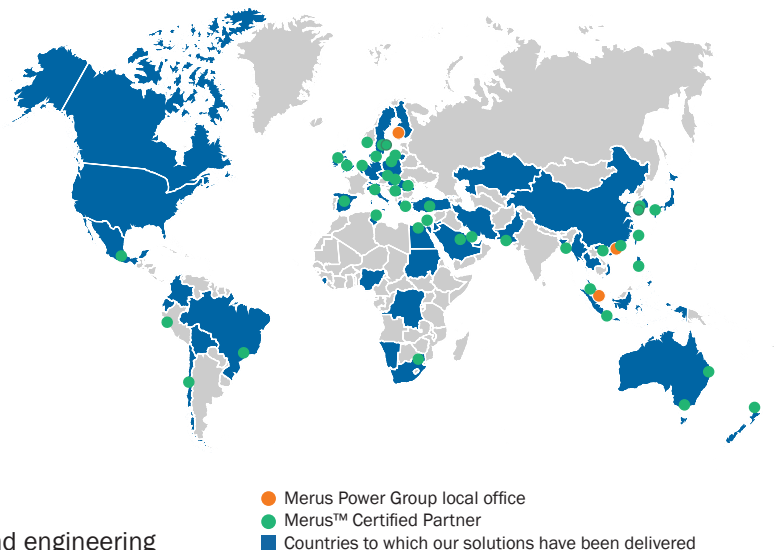

Merus™ A2-Active Harmonic Filters’ application and customer benefits

- **Variable frequency drives**

Variable frequency drives (VFD) are the most common source of harmonic currents in electrical networks. VFDs can be found in almost every larger building or factory. They can be used to control the speed of short-circuit motors that can be found in most electrical devices. A typical VFD consists of a 6-pulse diode bridge that produces a high number of harmonics in the network, and the total harmonic distortion (THDi) value can be over 60%.

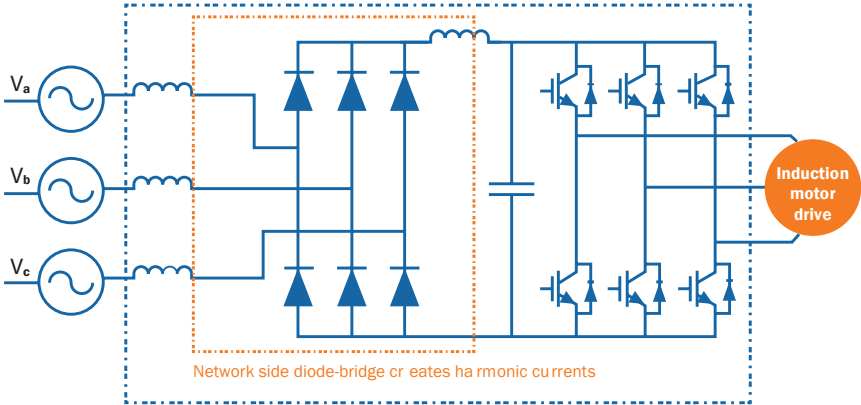

Typical VFD structure

If the 6-pulse drive harmonics are not mitigated, they can create high voltage distortion in the network and damage components. As 6-pulse drives produce multiple harmonics, any passive solution is often not used due to the space requirements and performance.

In active front-end drives (AFEs) the harmonic current on the network side is lower, but they are a costlier solution and are unable to compensate for multiple drives at once. A 6-pulse drive with Merus™ A2 is a more reliable and cheaper option, and this way multiple drives can be easily and simultaneously compensated for as well. The TCO cost of the AFE solution in each drive is higher than the standard 6-pulse drives and AHF in PCC.

Merus™ A2 performance is usually over 99% when compensating for 6-pulse drives, and it can keep the THDi under the required limits. We have optimized our active harmonic filter to work with typical variable frequency drives. By operating parallel to the VFD, Merus™ A2 keeps the feeder power quality in range. With the use of Merus™ A2 there is no need to worry about changes in the electrical network, as it is a dynamic solution. Merus™ A2 is easily integrable to operate with any VFD.

Main advantage:
Performance and scalable solution



• Industry

There are multiple different problematic power quality sources in industry besides VFDs. These are:

- AC-DC converters and DC drives
- DOL motors
- Welding applications
- Industrial process machines

Typical welding robots are installed between two phases. In some environments such as the mobile manufacturing industry, there can be hundreds of these robots in one factory. Welding typically takes only around 10 network cycles and during that time there is a big amount of reactive power, harmonics and unbalance in the network, and it causes voltage flickers and other problems.

Typically, any passive solution is too slow and cannot mitigate faster loads due to its response time. With a fast Merus™ A2 module, the voltage flicker, unbalance and harmonics can be mitigated in real time without worrying about the changes in the factory.

Main advantages: Load balancing and fast response time

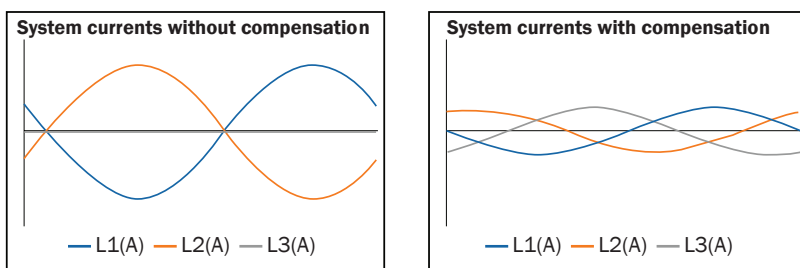

• Infrastructure

In infrastructure the loads are also between phases and neutral, resulting in 3 phases + neutral (4W-network) where there are loads also between phases and neutral. The typical loads for infrastructure are:

- AC/DC power supplies
- Lighting (LED & Fluorescent)
- Computers

These loads often generate abnormal neutral currents and heat up the neutral wires or generate other problems in the electrical network. If there are odd harmonics divisible by 3 in the network, they sum up in the neutral wire resulting in three times the phase current.

With Merus™ A2, you can also cancel neutral harmonics with the same device. Merus™ A2 allows the electrical network to work better, avoiding costly issues in critical applications such as hospitals and data centers.

Main advantages: 4W and proven product

“We obtained very positive results from our clients regarding the installation of Merus Power’s Active Harmonic Filters at critical locations, like various hospitals in the UK. Power quality was improved with the elimination of excessive harmonic distortion on the internal supply network. The outcome was a significant reduction in sensitive hospital equipment being impacted by power quality issues and fewer power protection devices being activated in such critical environments,” says Philip Alcorn, Managing Director of Alcorn Energy Systems, who is responsible for the full management of these projects as Merus Power’s partner.

- **Medium voltage**

Medium voltage can also suffer from harmonics. A typical example of a medium voltage harmonic problem is when converter-based renewable production is attached to the medium voltage network. Often the electrical grid owner has strict limits for the harmonic content from renewable plants and harmonics need to be mitigated below the limits on the medium voltage side.

Merus Power has a container solution for medium voltage installations, which can be fully tailored to customers' needs. Merus™ A2 medium voltage systems have been installed in multiple locations around the world and ensured renewable power grid connections.

When you are interested in medium voltage harmonic compensation contact Merus power sales, as MV applications typically require some studying and designing.

Most of the time, medium voltage applications require studying and designing beforehand, so please be in touch with our sales team regarding this matter. Our experts are happy to design a solution for you.

Main advantage: Medium voltage connectivity

“Merus Power’s 2700A Merus™ Active Harmonic Filter has been installed at the Jeffreys Bay Wind Facility in 2021 by RWW Engineering and all required utility harmonic limits have been met.”
– Kyle Lass, RWW Engineering

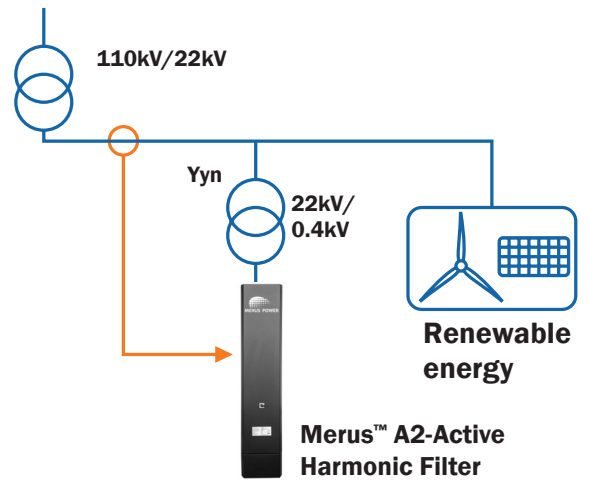

Our modular and scalable solution

Merus™ A2-Active Harmonic Filter

During our operating history of more than ten years, we have been continuously developing our technology and products to meet the needs of our customers in every way possible. We continue the development of new features to better our solutions every day.



3-level IGBT topology and design ensures:

- High performance
- Low heat losses
- Low noise

Easy to integrate:

- Integration for electrical cabinets
- Maintenance possibilities
- No external power supplies or controllers required

Capable to produce the nominal current at a typical harmonic spectrum

2 x ETHERNET + Modbus TCP

Smart features:

- Linear derating on temperature
- Automatic start and acknowledge
- Stand-by feature for power saving

Merus™ A2 is a proven product:

- Robust solution with long lifespan
- No master-slave topology issues
- High redundancy

One unit for:

- 3W/4W
- 50/60Hz
- Voltage levels (200...480 and 480...690)

Preprogrammed digital input and outputs for hardwired signals

Multiple modules in parallel

- Both open & closed loop CT configurations

UL508 and CSA rated modules

Smart and advanced HMI

with easy-to-use features

Merus™ A2 are equipped with advanced 7" touchscreen Human Machine Interface (HMI).

- All essential functions on home screen
- Automatic screensaver with lock for different user levels
- Up to 7 module connections in one HMI

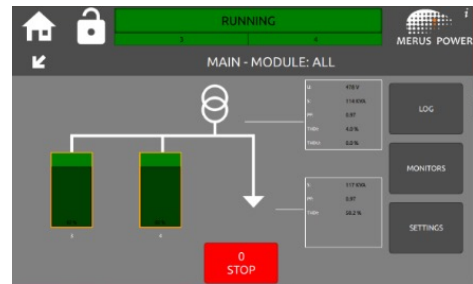

Easy commissioning wizard helps users through the commissioning process.



Simple event log without cryptic codes.

DATE	MODULE	TYPE	DESCRIPTION
2020-03-18 09:30:37	ALL	STATES	TRIP
2020-03-18 09:30:36	1	TRIPS	TRIP VOLTAGE OR FREQUENCY IS NOT CONFIRMED
2020-03-18 09:30:36	1	STATES	TRIP
2020-03-18 09:30:33	1	PARAMETERS	CONFIRMED FREQUENCY
2020-03-18 09:30:21	ALL	STATES	RUNNING
2020-03-18 09:30:21	1	STATES	RUNNING

USB-drive upload and download possibility

- No additional devices required

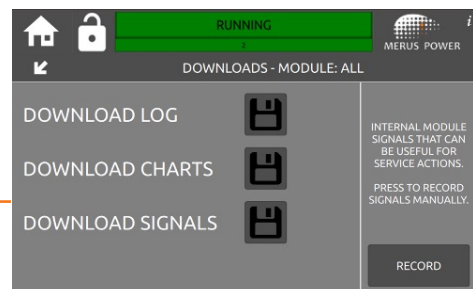

Easy-to-use and multilingual (more languages upon request)

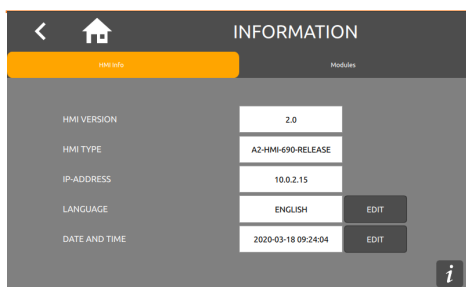

Trend recordings

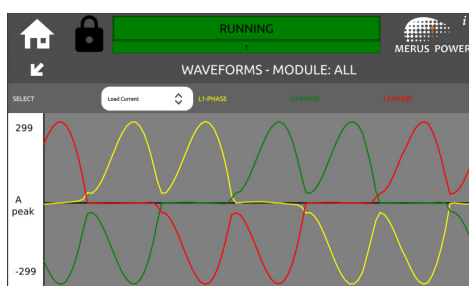
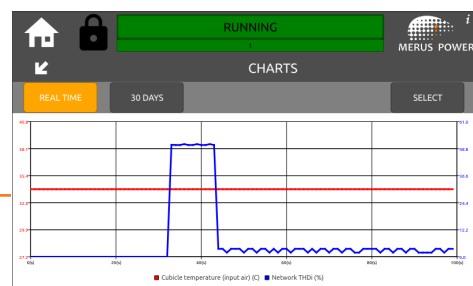

Monitors on both network and load sides

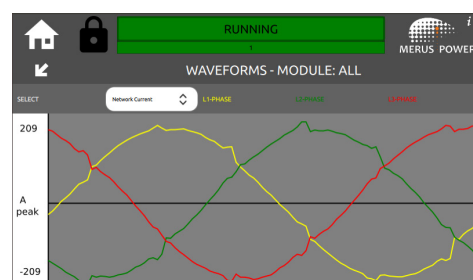

Merus™ A2-HPQ

Hybrid Power Quality – Cost-efficient solution for dynamic reactive power and harmonic mitigation



Merus™ HPQ is a hybrid power quality compensator. Its operation is based on two main components: a detuned capacitor bank and an active harmonic filter. In Merus™ HPQ all-in-one solution, the Merus™ A2-series Active Harmonic Filter operates as a power factor correction (PFC) controller for the capacitor bank and utilizes detuned capacitor steps to fulfill most capacitive reactive power needs. While the Merus™ A2 module handles the intermediate steps and inductive reactive power, it filters the harmonic currents and balances the unbalanced currents.

Merus™ HPQ is the perfect solution to replace old capacitor banks with economical and reliable 21st-century technology.

- Stepless and fast power factor correction
- Harmonic current mitigation
- Imbalance correction
- **Saves money and improves power quality**
 - Cost reduction is achieved by upgrading compensation devices with 21st-century technology
 - Better power quality: fewer interruptions and faults
 - Better and faster power factor control: reduced electricity bills and fewer problems
- **No unnecessary small steps to capacitor banks**
 - Dynamic parts ensure that smaller steps by the capacitor bank are not needed
 - All-in-one solution – no separate controllers required
 - Higher effective compensation compared to traditional separate compensation systems
- **Extends the lifespan of equipment**
 - Increased lifespan of equipment in the network, due to harmonic mitigation.
 - The capacitor bank's lifespan increases as the voltage harmonics are mitigated
- **Integration**
 - The solution is easy to integrate into a standard capacitor cubicle
 - Well suited to OEM cabinet builders
 - Suitable even for retrofit installations
- **Modern and user-friendly interface**
 - Easy-to-use HMI
 - Provides additional information about system status
 - Trend recordings give more value and understanding
 - Remote monitoring option

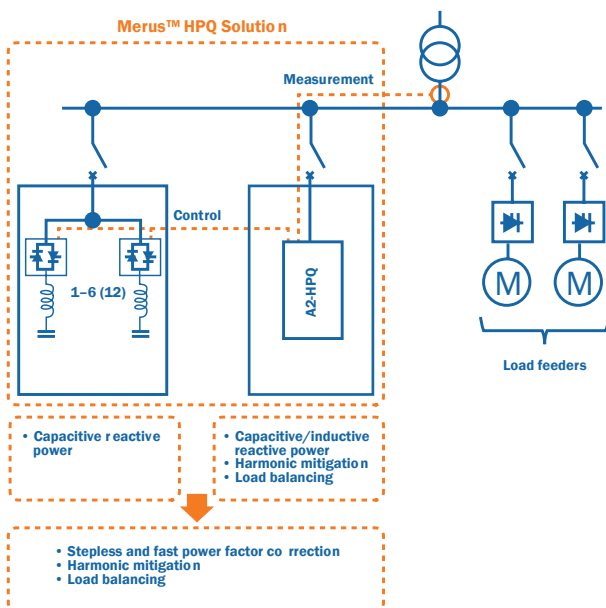

Merus™ A2 offering

Module offering

Current rating (A)	50 A	100 A	150 A	200 A	50 A	100 A	125 A
Voltage rating (A)	200...480 VAC 3W 200...440 VAC 4W	200...480 VAC 3W 200...440 VAC 4W	200...480 VAC 3W 200...440 VAC 4W	200...480 VAC 3W 200...440 VAC 4W	480...690 VAC 3W 480...525 VAC 4W	480...690 VAC 3W 480...525 VAC 4W	480...690 VAC 3W 480...525 VAC 4W
Dimensions (WxDxH in mm)	225x500x850 mm ³	225x500x850 mm ³	225x500x1,150 mm ³	225x500x1,150 mm ³	225x500x1,150 mm ³	225x500x1,150 mm ³	225x500x1,150 mm ³
Weight	70 kg	70 kg	110 kg	110 kg	110 kg	110 kg	110 kg
IP rating	IP 20	IP 20	IP 20	IP 20	IP 20	IP 20	IP 20

Detailed datasheets can be found as an appendix.

We also offer several add-ons for the modules, such as:

- IP30 kit
- HPQ control system

Total solutions with cabinets

Merus Power offers standard cabinets for integration. Our ranges for standard cabinets are:

- 50-800 A cabinets for 200-480 VAC modules
- 50-500 A cabinets for 480-690 VAC modules

Medium voltage applications

Merus™ A2-module solutions are possible to install in medium voltage applications with a suitable step-up transformer. This allows e.g., renewable power production to meet the network owner criteria for harmonics in PCC.

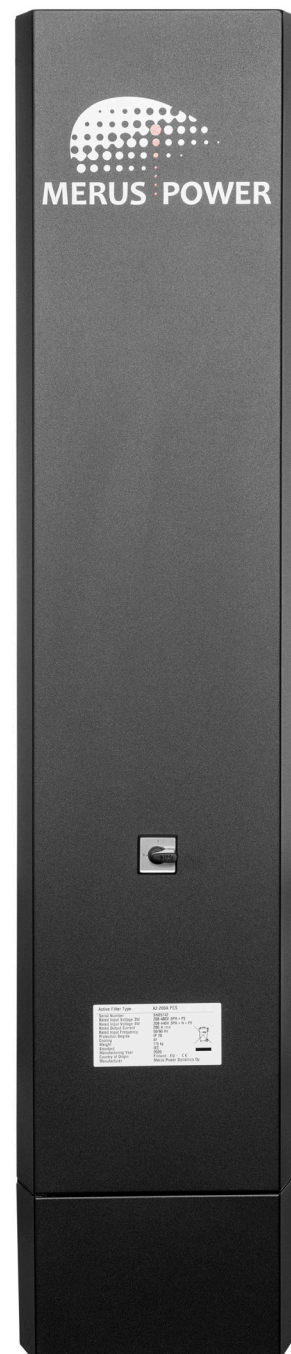

Merus Power

Electrify your Future

Merus Power is a global green technology company headquartered in the city of Nokia, Finland. We design, manufacture, sell and provide power quality systems and services as well as Finnish innovative electrical energy storages. Scalable and modular power electronics, intelligent software technologies and electrical engineering expertise are the basis of our business.

Merus™ Solutions can be easily tailored to a variety of applications and can meet small and large-scale customer needs with their modular structures. Their compact size, design and scalability allow simple and cost-effective integration into many electrical systems.

Over the years we have worked with various customers in industry, utility, infrastructure and renewable energy applications in 59 different countries.



Send us an email to sales@meruspower.com.
One of our sales reps will be in touch with you as soon as possible.

Merus Power Plc | www.meruspower.com | sales@meruspower.com | Pirkkalaistie 1, 37100 Nokia, Finland

TECHNICAL DATA FOR CORE PRODUCTS

Nominal current capacity	50 A	100 A	150 A	200 A
Nominal voltage	3W configuration: 200 VAC - 480 VAC ($\pm 10\%$), 4W configuration: 200 - 440 VAC ($\pm 10\%$) higher voltages with suitable step-up transformer			
Harmonics filtering	2 nd to 50th harmonics. Fully selectable and programmable up to 25 th harmonic order in 'selectable' mode (standard deliveries).			
Interharmonic filtering	Interharmonics are filtered up to the 50th harmonic order when operating in 'all harmonics' or 'all harmonics but not fundamental' modes.			
Filtering performance	Typically, <5% THDi even with the most complex loads. <3% THDi reachable (reduction with load harmonic above 50% module rating and the nonlinear load has >3% inductive impedance)			
Operation modes	All harmonics/All harmonics but not fundamental/Selectable harmonics			
Reaction / Response time	Reaction time <50 μ s / Response time <100 μ s (1 network cycle in selectable mode)			
Parallel modules	Unlimited scalability. Load is shared evenly between parallel modules			
Switching frequency	20 kHz			
Controller	Real time digital control with FFT			
Redundancy	Each module has independent controller. If one module fails, the rest keep operating			
Load balancing capacity	Programmable 0...100% * IN of the module			
Max neutral wire current	150 A	300 A	450 A	600 A
Network (3-wire/4-wire)	3W/4W			
HMI / display	7" touch screen with multilingual graphical HMI			
Connections for HMI	1...7 module connections in one HMI. Unlimited number of HMIs			
HMI languages	English-German-Spanish-Chinese (T)-Chinese (S)-Russian-Japanese-Turkish-Polish. Others on request.			
Monitoring and reporting	On-site and remote monitoring capabilities Waveforms and spectrums from both load and network sides Trend charts			
Communication capability	Ethernet, USB, Modbus TCP/IP			
Cooling method	Forced air by temperature-controlled fans			
Protection degree	IP 20, up to IP54 depending on the enclosure Pollution degree 2 Conformal coating on all PCBAs			
Temperature	5-40 °C, without derating. Max ambient temperature 50 °C			
Humidity	Maximum 85% RH, non-condensing (operation) Maximum 95% RH, non-condensing (storage)			
Losses	<2.3%			
Dimension (WxDxH)	(225x500x850)mm	(225x500x850)mm	(225x500x1150)mm	(225x500x1150)mm
Weight	70 kg	70 kg	110 kg	110 kg
Main cable entry	Top/Bottom			
Typical noise at full load	60 dB	64 dB	67 dB	68 dB
CT locations	No audible switching frequency noise Network/load side			
Number of CT's	3 pcs / 6 pcs			
CT polarity change	Installed CT polarity can be changed without HW changes in the network			
Minimum CT accuracy class	1.0 or better			
CT-primary/secondary	Primary: no limitations. Secondary: load currents: 1A/5A, auxiliary currents: 5A.			
Ventilation requirements	300mm free space below and above the module required for air ventilation			
External fuses (recommendation)	NH 00 gL/gG 63A	NH 00 gL/gG 125A	NH 01 gL/gG 200A	NH 01 gL/gG 250A

TECHNICAL DATA FOR 690 VAC MODULES

Nominal current capacity	50 A	100 A	125 A
Nominal voltage	3W configuration: 500 VAC – 690 VAC (±10%), 4W configuration: 480 – 525 VAC (±10%)		
	higher voltages with suitable step-up transformer		
Harmonics filtering	2 nd to 50 th harmonics. Fully selectable and programmable up to 25 th harmonic order in 'selectable' mode (standard deliveries).		
Interharmonic filtering	Interharmonics are filtered up to the 50 th harmonic order when operating in 'all harmonics' or 'all harmonics but not fundamental' - modes.		
Filtering performance	Typically, <5% THDi even with the most complex loads.		
	<3% THDi reachable (reduction with load harmonic above 50% module rating and the nonlinear load has >3% inductive impedance)		
Operation modes	All harmonics/All harmonics but not fundamental/Selectable harmonics		
Reaction / Response time	Reaction time <50 µs / Response time <100 µs (1 network cycle in selectable mode)		
Parallel modules	Unlimited scalability. Load is shared evenly between parallel modules		
Switching frequency	20 kHz		
Controller	Real time digital control with FFT		
Redundancy	Each module has independent controller. If one module fails, the rest keep operating		
Load balancing capacity	Programmable 0...100% * IN of the module		
Max neutral wire current	150 A	300A	375 A
Network (3-wire/4-wire)	3W/4W		
HMI / display	7" touch screen with multilingual graphical HMI		
Connections for HMI	1...7 module connections in one HMI. Unlimited number of HMIs		
HMI languages	English-German-Spanish-Chinese (T)-Chinese (S)-Russian-Japanese-Turkish-Polish. Others on request.		
Monitoring and reporting	On-site and remote monitoring capabilities		
	Waveforms and spectrums from both load and network sides		
	Trend charts		
Communication capability	Ethernet, USB, Modbus TCP/IP		
Cooling method	Forced air by temperature-controlled fans		
Protection degree	IP 20, up to IP54 depending on the enclosure		
	Pollution degree 2		
	Conformal coating on all PCBAs		
Temperature	5-40 °C, without derating. Max ambient temperature 50 °C		
Humidity	Maximum 85% RH, non-condensing (operation)		
	Maximum 95% RH, non-condensing (storage)		
Losses	<2.5%		
Dimension (WxDxH)	(225x500x1150)mm	(225x500x1150)mm	(225x500x1150)mm
Weight	110 kg	110 kg	110 kg
Main cable entry	Top/Bottom		
Typical noise at full load	<70 dB	<75 dB	<75 dB
	No audible switching frequency noise		
CT-locations	Network/load side		
Number of CTs	3 pcs / 6 pcs		
CT-polarity change	Installed CT-polarity can be changed without HW changes in the network		
Minimum CT accuracy class	1.0 or better		
CT-primary/secondary	Primary: no limitations.		
	Secondary: load currents: 1A/5A, auxiliary currents: 5A.		
Ventilation requirements	300mm free space below and above the module required for air ventilation		
External fuses (recommendation)	NH 01 gL/gG 63A	NH 01 gL/gG 125A	NH 01 gL/gG 160A